

Engine Control Module (ECM) X3 (LGH or LML)

Connector Close to  
Fire wall

Yellow wire from #11  
and use yellow wire  
from switch

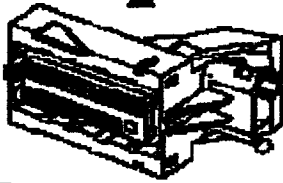
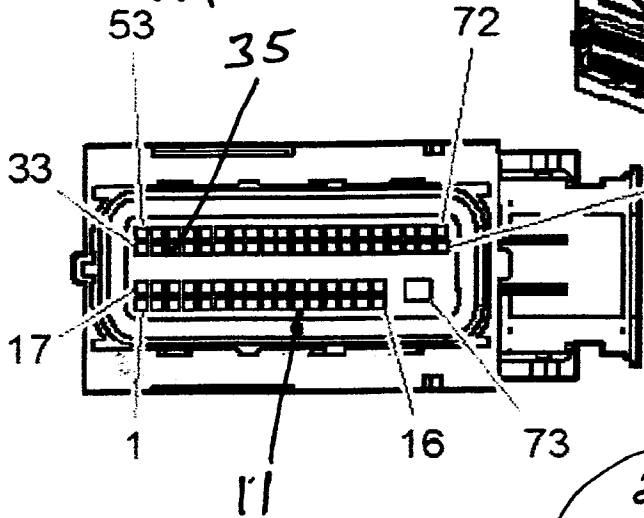

2011-2014  
#11 yellow  
#35 Black  
5 Position  
Switch

2015-2016  
Blue to #11  
White to #35  
4 Position  
Switch

**Connector Part Information**

- Harness Type: Engine Chassis
- OEM Connector: 12603597
- Service Connector: 13574948
- Description: 73-Way F MX123 34566 Series, Sealed (GY)

**Terminal Part Information**

- Pins: 2-7, 9-16, 18-21, 24-25, 27-32, 36-38, 40, 44, 46, 48-52, 54-62, 64-72
- Terminated Lead: Not Available
- Release Tool: J-38125-213
- Diagnostic Test Probe: J-35616-64B (L-BU)
- Terminal/Tray: 33467-0005/23
- Core/Insulation Crimp: Pins: 2-7, 9-16, 18-21, 24-25, 27-32, 36-38, 40, 44, 46, 48, 54-55, 58-62, 64-68 - J/J
- Core/Insulation Crimp: Pins: 49-52, 56-57, 69-72 - K/K
  
- Pin 73
- Terminated Lead: 13576375
- Release Tool: J-38125-11A
- Diagnostic Test Probe: J-35616-35 (VT)
- Terminal/Tray: 7116-4152-02/9
- Core/Insulation Crimp: A/5

**Engine Control Module (ECM) X3 (LGH or LML)**  
© 2015 General Motors. All rights reserved.

Engine Control Module (ECM) X3 (LGH or LML)

Connector Close to  
Fire wall

Yellow wire from #11  
and use yellow wire  
from switch

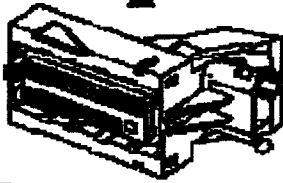
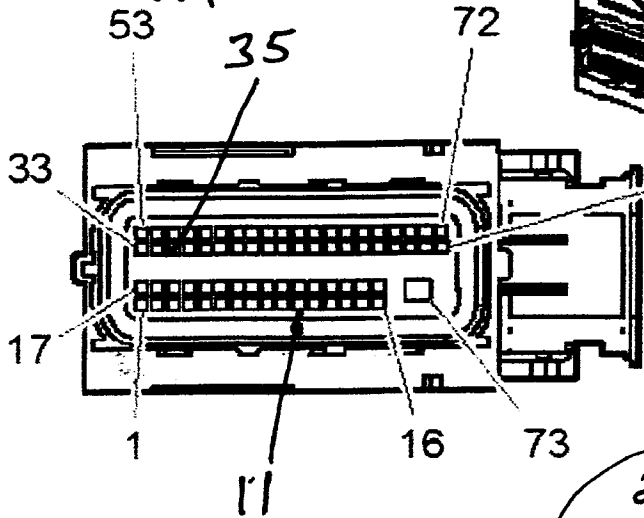

2011-2014  
#11 yellow  
#35 Black  
5 Position  
Switch

2015-2016  
Blue to #11  
White to #35  
4 Position  
Switch

**Connector Part Information**

- Harness Type: Engine Chassis
- OEM Connector: 12603597
- Service Connector: 13574948
- Description: 73-Way F MX123 34566 Series, Sealed (GY)

**Terminal Part Information**

- Pins: 2--7, 9-16, 18-21, 24-25, 27-32, 36-38, 40, 44, 46, 48-52, 54-62, 64-72
- Terminated Lead: Not Available
- Release Tool: J-38125-213
- Diagnostic Test Probe: J-35616-64B (L-BU)
- Terminal/Tray: 33467-0005/23
- Core/Insulation Crimp: Pins: 2-7, 9-16, 18-21, 24-25, 27-32, 36-38, 40, 44, 46, 48, 54-55, 58-62, 64-68 - J/J
- Core/Insulation Crimp: Pins: 49-52, 56-57, 69-72 - K/K
  
- Pin 73
- Terminated Lead: 13576375
- Release Tool: J-38125-11A
- Diagnostic Test Probe: J-35616-35 (VT)
- Terminal/Tray: 7116-4152-02/9
- Core/Insulation Crimp: A/5

**Engine Control Module (ECM) X3 (LGH or LML)**

© 2015 General Motors. All rights reserved.